

K SINGLE-IMPELLER

SINGLE-IMPELLER ELECTRIC PUMPS



TECHNICAL DATA

Operating range:

from 1,8 to 96 m³/h, with head up to 62 metres.

Pumped liquid: clean, free of solids and abrasives, non-viscous, non-aggressive, non-crystallised and chemically neutral, with properties similar to water.

Liquid temperature range:

K 20/41, K 30/70, K 30/100, K 36/100

K 12/200, K 36/200, K 40/200 :

from -10 °C to +50 °C

Remainder of the range:

from -15 °C to +110 °C

Maximum ambient temperature: +40°C

Maximum operating pressure:

K 20/41, K 30/70, K 30/100, K 36/100, K 12/200, K 14/400 : 6 bar (600 kPa)

K 36/200, K 40/200, K 55/200, K 11/500, K 18/500, K 28/500 : 8 bar (800 kPa)

K 40/400, K 50/400, K 30/800, K 40/800, K 50/800,

: 10 bar (1000 kPa)

Protection class:

IP 44 (IP 55 for 2,2 - 3 - 4 - 5,5 - 7,5 - 9,2 - 11 kW motors)

Protection class at the terminal board: IP 55

Insulation class: F

Standard voltage:

single-phase 220-240 V / 50 Hz

three-phase 230-400 V / 50 Hz up to 4 kW included - 400 V Δ 50 Hz from 5,5 kW

Installation: horizontal or vertical position, provided that the motor is always above the pump.

Special executions on requests: alternative voltages and frequencies.

APPLICATIONS

Single-impeller centrifugal pump suitable for domestic, civil, industrial and agricultural systems, and for decanting, mixing and irrigation uses.

CONSTRUCTION FEATURES OF THE PUMP

Pump body and motor support in cast iron.

Technopolymer or cast iron impeller, as per the TECHNICAL DATA table.

Carbon/ceramic mechanical seal.

CONSTRUCTION FEATURES OF THE MOTOR

Closed asynchronous type, external ventilation cooling.

Rotor running on ball bearings, oversized to ensure low noise and durability.

Standard built-in thermo-amperometric protection. Capacitor permanently fitted on single phase versions.

For the protection of the three-phase motor, we recommend the use of remote overload cut-outs, in compliance with current local regulations.

Construction according to CEI 2-3.

IE2 motors as standard, from 0,75 kW to 5,5 kW - IE3 ≥ 7,5 kW

K SINGLE-IMPELLER

SINGLE-IMPELLER ELECTRIC PUMPS

MATERIALS

No.	PARTS*	MATERIALS	MODELS
1	PUMP BODY	CAST IRON 200 UNI ISO 185	
3	SUPPORT	CAST IRON 200 UNI ISO 185	
4	IMPELLER	TECHNOPOLYMER A	20/41; K 30/70; K 30/100; K 36/100; K 12/200; K 36/200; K 40/200;
		TECHNOPOLYMER B	K 55/200
		CAST IRON 200 UNI ISO 185	K 14/400; K 11/500; K 18/500; K 28/500; K 40/400; K 50/400; K 30/800; K 40/800; K 50/800; K 20/1200; K 25/1200; K 35/1200;
7	SHAFT WITH ROTOR	AISI 416 STAINLESS STEEL X12CRS13 UNI 6900/71	K 20/41; K 30/70; K 12/200
		AISI 303 STAINLESS STEEL X10CRN15 UNI 6900/71	K 30/100; K 36/100; K 36/200; K 40/200; K 55/200; K14/400; K 11/500; K 18/500; K 28/500
		AISI 304 STAINLESS STEEL X5CRN1 1810 UNI 6900/71	K 40/400; K 50/400; K 30/800; K 40/800; K 50/800; K 20/1200; K 25/1200; K 35/1200;
16	MECHANICAL SEAL	CARBON / CERAMIC	
28	OR RING	NBR RUBBER	
		EPDM RUBBER	K 36/200; K 40/200; K 55/200; K 14/400; K 11/500; K 18/500; K 28/500; K 30/800; K 40/800; K 50/800; K 20/1200; K 25/1200; K 35/1200;

* In contact with the liquid

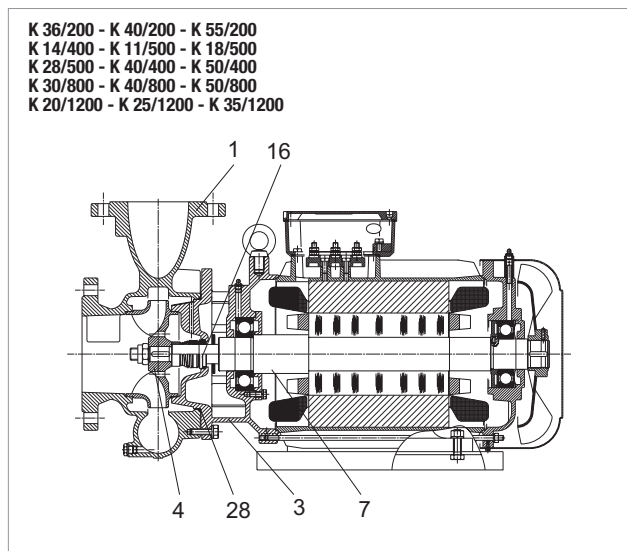
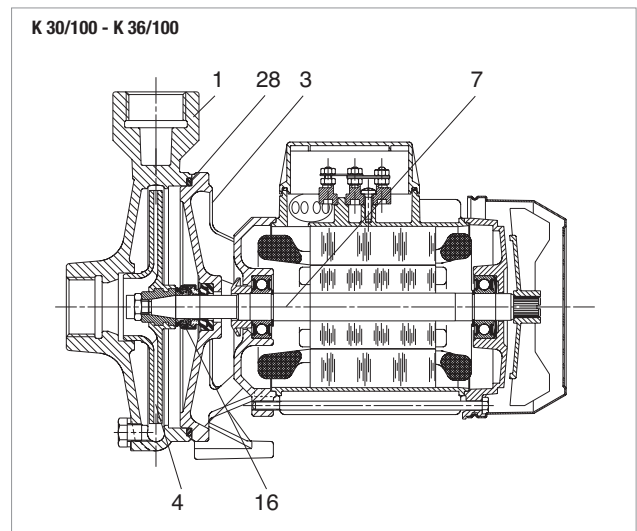
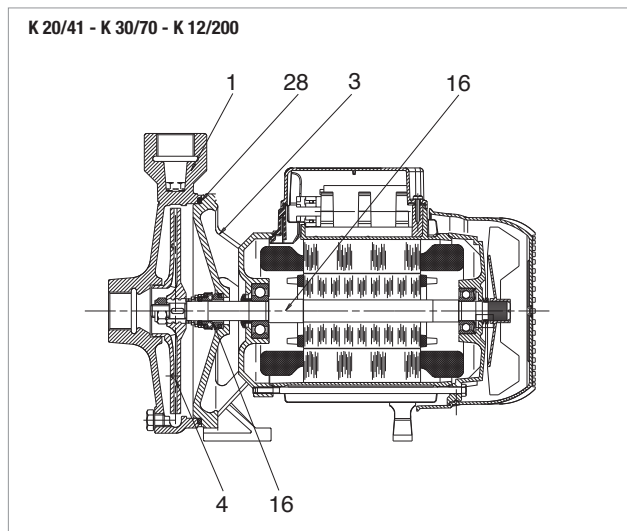

K SINGLE-IMPELLER RANGE

ELECTRIC PUMPS

PERFORMANCE RANGE

The performance curves are based on kinematic viscosity values = 1 mm²/s and density equal to 1000 kg/m³. Curve tolerance according to ISO 9906.

GRAPHIC SELECTION TABLE

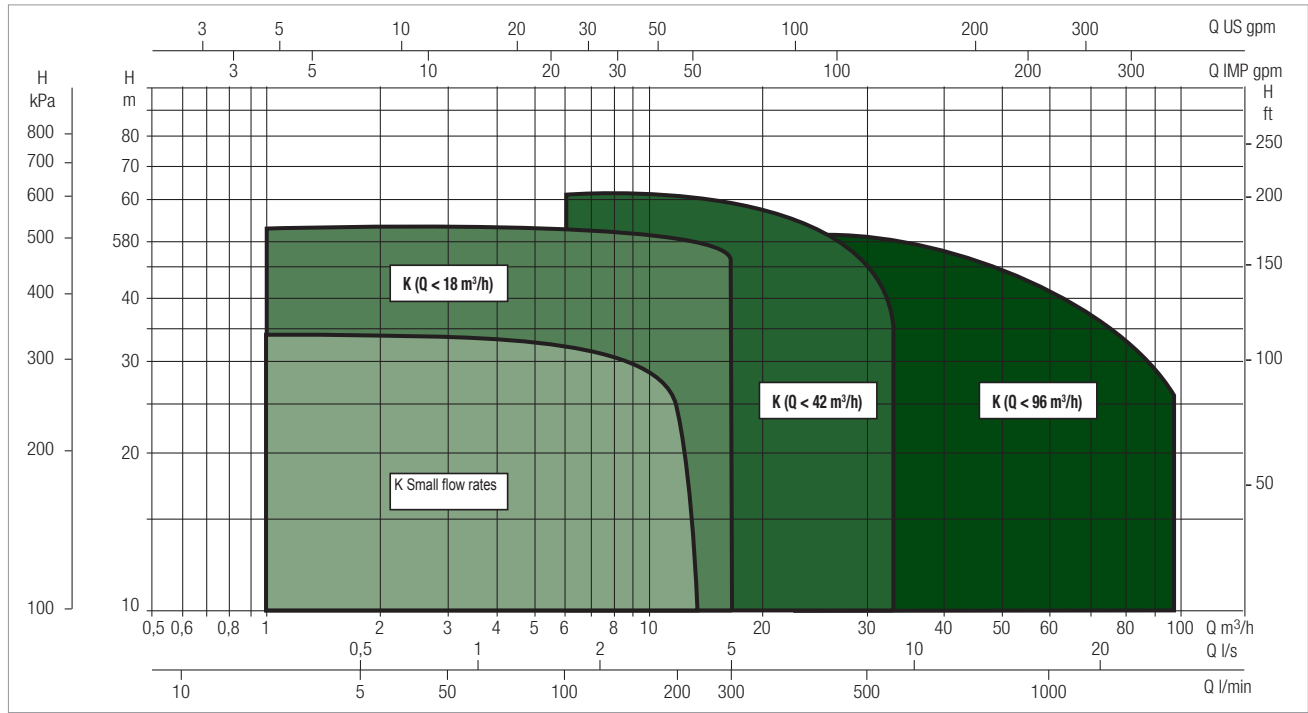

SELECTION TABLE

MODEL	Q=	0	1.8	2.4	3.6	4.8	6	7.2	9	9.6	10.8	12	15	18	24	30	36	42	60	72	84	96	
	m ³ /h	0	30	40	60	80	100	120	150	160	180	200	250	300	400	500	600	700	1000	1200	1400	1600	
K 20/41 M-T	H (m)	22	20.3	19.4	16.9	13.6	8.3																
K 30/70 M-T		31.8	29.5	28.9	27	24.2	19.8	13.5															
K 30/100 M-T		29.2		29	28.8	28	26.8	25.3	22.5	21.5	18.5												
K 36/100 M-T		34.9		34.8	34.6	34	33	32	29.8	29	26.5												
K 12/200 M-T		18.7	18.2	18	17.9	17.7	17.4	17	16.1	15.8	14.9	14	11.2	7.7									
K 36/200 T		36.6				36	35.5	35	34	33.3	32.5	31.5	28	23.5									
K 40/200 T		41.3				41	40.5	40	39	38.8	38	37	33.5	29									
K 55/200 T		54				54	53.9	53.2	53	52	51.5	48.5	45										
K 14/400 M-T		19									18.8	18.5	18	16.3	13.8	10							
K 11/500 T		25.1									26	25.6	25.2	22.9	18.7	13.7	7.7						
K 18/500 T		30.9									32	31.8	30	28.5	25	19.3	13.1						
K 28/500 T		35.4									36.6	36.1	35.6	33.2	30.1	24.7	18.1						
K 40/400 T		50.5									49	48	45	37	24								
K 50/400 T		62									61	60	59	54.5	46								
K 30/800 T		44												42	40	38	35	21.5					
K 40/800 T		51.5												50	48	47	43.5	32.5	21				
K 50/800 T		58												56.5	55	53.5	51	41	31				
K 20/1200 T		37.5													36.5	36	35	34	30	26	21	15	
K 25/1200 T		40.7													39	38.5	38	37	33.5	30	25	18	
K 35/1200 T		45														43	42.5	38.5	35	31.5	27		

K 20/41 - SINGLE-IMPELLER CENTRIFUGAL ELECTRIC PUMPS FOR WATER SUPPLY IN DOMESTIC, CIVIL, AND INDUSTRIAL ENVIRONMENTS

Pumped liquid temperature range: from -10 °C to +50°C - Maximum ambient temperature: +40°C

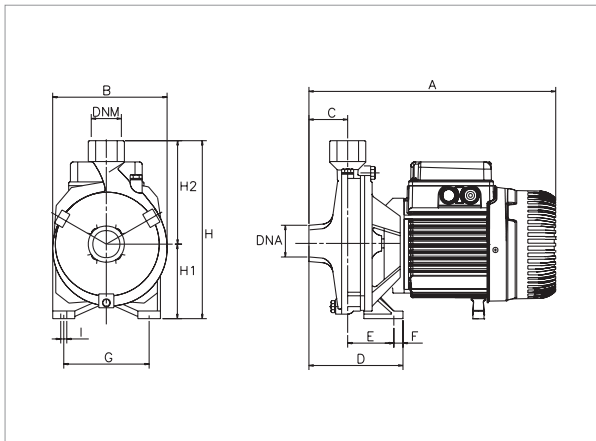

See hydraulic efficiency details on page 291.

The performance curves are based on kinematic viscosity values = 1 mm²/s and density equal to 1000 kg/m³. Curve tolerance according to ISO 9906.

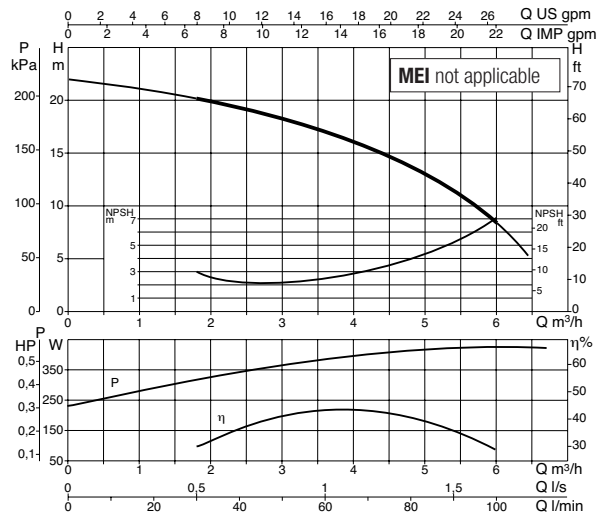

MODEL	ELECTRICAL DATA									
	POWER INPUT 50 Hz	P1 MAX kW	P2 NOMINAL		In A	MOTOR TYPE	I st. A	rpm n. 1/min.	CAPACITOR	
			kW	HP					μF	Vc
K 20/41 M	1x220-240 V ~	0.65	0.37	0.5	3	-	8.5	2800	10	450
K 20/41 T	3x230-400 V ~	0.64	0.37	0.5	2.3-1.3	-	8.6-5	2800	-	-

MODEL	A	B	C	D	E	F	G	ØI	H	H1	H2	DNA	DNM	PACKING DIMENSIONS			VOLUME (m ³)	WEIGHT kg
														L/A	L/B	H		
K 20/41	275	160	50	100	50	15	110	9	205	85	120	1" G	1" G	332	202	257	0.024	10

K 30/70 - SINGLE-IMPELLER CENTRIFUGAL ELECTRIC PUMPS FOR WATER SUPPLY IN DOMESTIC, CIVIL, AND INDUSTRIAL ENVIRONMENTS

Pumped liquid temperature range: from -10 °C to +50°C - Maximum ambient temperature: +40°C

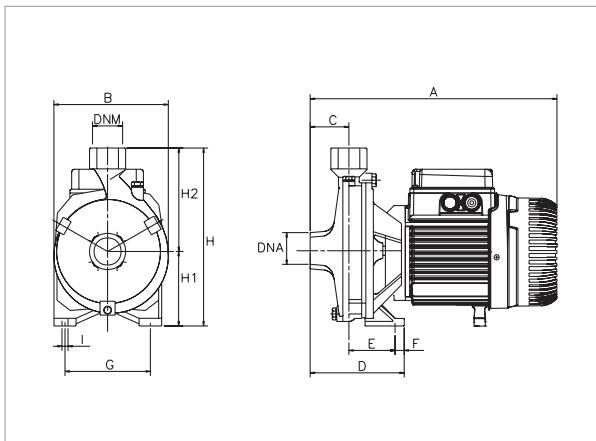

See hydraulic efficiency details on page 291.

The performance curves are based on kinematic viscosity values = 1 mm²/s and density equal to 1000 kg/m³. Curve tolerance according to ISO 9906.

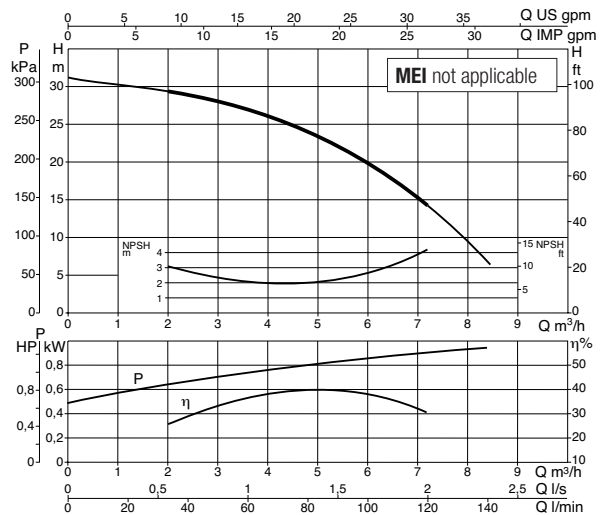

MODEL	ELECTRICAL DATA									
	POWER INPUT 50 Hz	P1 MAX kW	P2 NOMINAL		In A	MOTOR TYPE	I st. A	rpm n. 1/min.	CAPACITOR	
			kW	HP					μF	Vc
K 30/70 M	1x220-240 V ~	1.3	0.75	1	6	-	15.8	2800	20	450
K 30/70 T	3x230-400 V ~	1.2	0.75	1	4.3-2.5	IE2	22.1-12.8	2820	-	-

MODEL	A	B	C	D	E	F	G	ØI	H	H1	H2	DNA	DNM	PACKING DIMENSIONS			VOLUME (m ³)	WEIGHT kg
														L/A	L/B	H		
K 30/70	330	185	50	108	58	15	140	9	235	100	135	1" G	1" G	386	226	272	0.024	13.9

K 30/100 - SINGLE-IMPELLER CENTRIFUGAL ELECTRIC PUMPS FOR WATER SUPPLY IN DOMESTIC, CIVIL, AND INDUSTRIAL ENVIRONMENTS

Pumped liquid temperature range: from -10 °C to +50°C - Maximum ambient temperature: +40°C

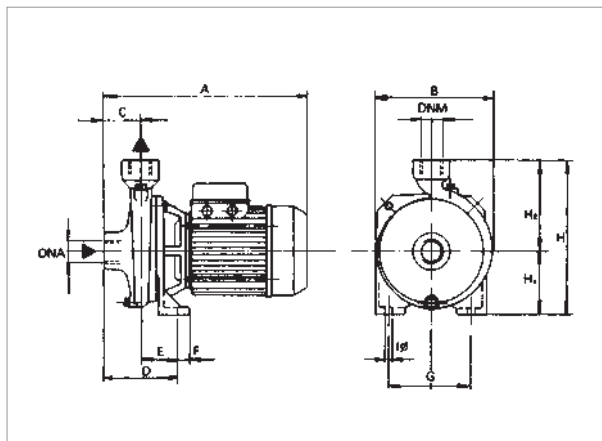

See hydraulic efficiency details on page 291.

The performance curves are based on kinematic viscosity values = 1 mm²/s and density equal to 1000 kg/m³. Curve tolerance according to ISO 9906.

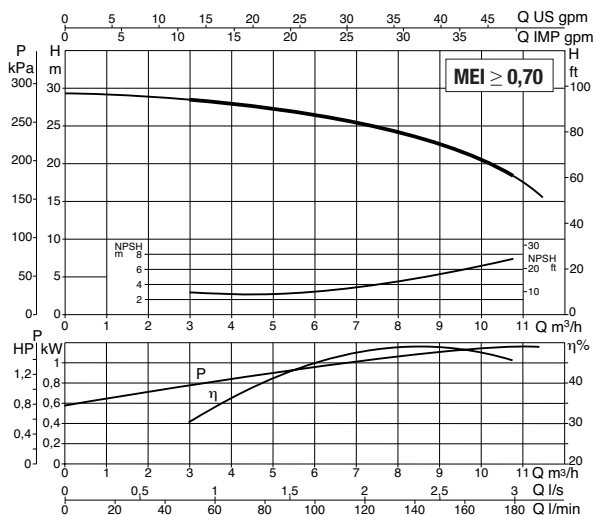

MODEL	ELECTRICAL DATA									
	POWER INPUT 50 Hz	P1 MAX kW	P2 NOMINAL		In A	MOTOR TYPE	I st. A	rpm n. 1/min.	CAPACITOR	
			kW	HP					μF	Vc
K 30/100 M	1x220-240 V ~	1.6	1.1	1.5	7.1	-	33	2800	31.5	450
K 30/100 T	3x230-400 V ~	1.63	1.1	1.5	6.9-3.9	IE2	21	2860	-	-

MODEL	A	B	C	D	E	F	G	ØI	H	H1	H2	DNA	DNM	PACKING DIMENSIONS			VOLUME (m ³)	WEIGHT kg
														L/A	L/B	H		
K 30/100	333	200	50	114	64	15	140	9	255	105	150	1½" G	1" G	427	246	307	0.032	18.5

K 36/100 - SINGLE-IMPELLER CENTRIFUGAL ELECTRIC PUMPS FOR WATER SUPPLY IN DOMESTIC, CIVIL, AND INDUSTRIAL ENVIRONMENTS

Pumped liquid temperature range: from -10 °C to +50°C - Maximum ambient temperature: +40°C

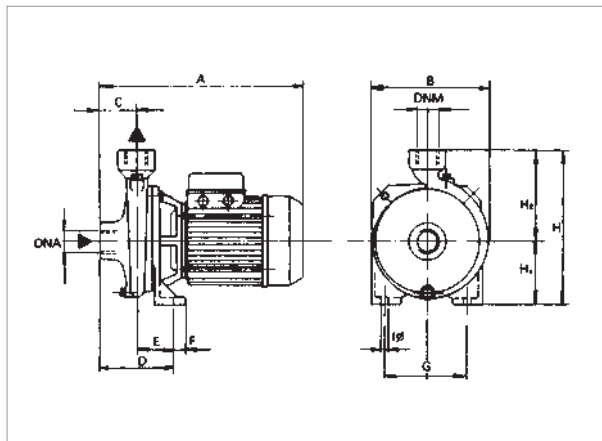

See hydraulic efficiency details on page 291.

The performance curves are based on kinematic viscosity values = 1 mm²/s and density equal to 1000 kg/m³. Curve tolerance according to ISO 9906.

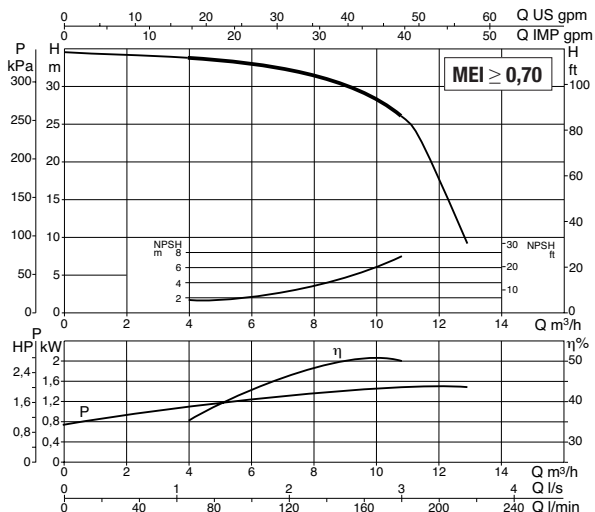

MODEL	ELECTRICAL DATA									
	POWER INPUT 50 Hz	P1 MAX kW	P2 NOMINAL		In A	MOTOR TYPE	I st. A	rpm n. 1/min.	CAPACITOR	
			kW	HP					μF	Vc
K 36/100 M	1x220-240 V ~	2.1	1.85	2.5	8.8	-	45	2850	40	450
K 36/100 T	3x230-400 V ~	2	1.85	2.5	6.9-4	IE2	22	2870	-	-

MODEL	A	B	C	D	E	F	G	ØI	H	H1	H2	DNA	DNM	PACKING DIMENSIONS			VOLUME (m ³)	WEIGHT kg
														L/A	L/B	H		
K 36/100	333	200	50	114	64	15	140	9	255	105	150	1½" G	1" G	427	246	307	0.032	23.3

K 12/200 - SINGLE-IMPELLER CENTRIFUGAL ELECTRIC PUMPS FOR WATER SUPPLY IN DOMESTIC, CIVIL, AND INDUSTRIAL ENVIRONMENTS

Pumped liquid temperature range: from -10 °C to +50°C - Maximum ambient temperature: +40°C

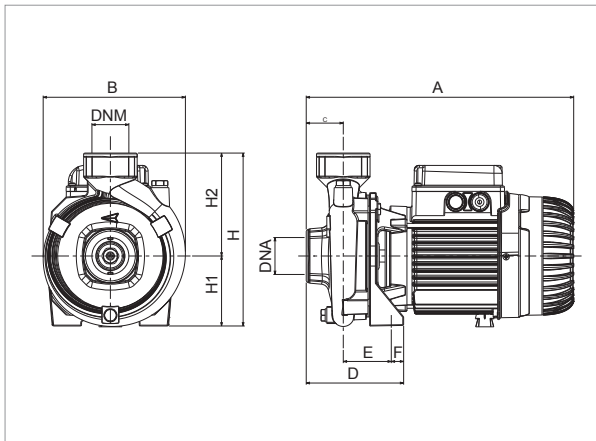

See hydraulic efficiency details on page 291.

The performance curves are based on kinematic viscosity values = 1 mm²/s and density equal to 1000 kg/m³. Curve tolerance according to ISO 9906.

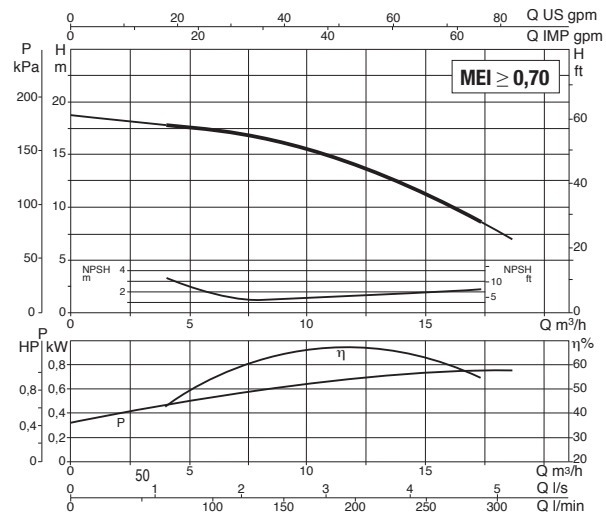

MODEL	ELECTRICAL DATA									
	POWER INPUT 50 Hz	P1 MAX kW	P2 NOMINAL		In A	MOTOR TYPE	I st. A	rpm n. 1/min.	CAPACITOR	
			kW	HP					μF	Vc
K 12/200 M	1x220-240 V ~	1.1	0.75	1	5.2	-	18.5	2940	25	450
K 12/200 T	3x230-400 V ~	0.97	0.75	1	4-2.3	IE2	22.1-12.8	2940	-	-

MODEL	A	B	C	D	E	F	G	ØI	H	H1	H2	DNA	DNM	PACKING DIMENSIONS			VOLUME (m ³)	WEIGHT kg
														L/A	L/B	H		
K 12/200	325	173	45	118	58	15	110	9.5	218	85	125	1 1/2	1 1/2	392	232	280	0,026	13.7

K 36/200 - SINGLE-IMPELLER CENTRIFUGAL ELECTRIC PUMPS FOR WATER SUPPLY IN DOMESTIC, CIVIL, AND INDUSTRIAL ENVIRONMENTS

Pumped liquid temperature range: from -10 °C to +50°C - Maximum ambient temperature: +40°C

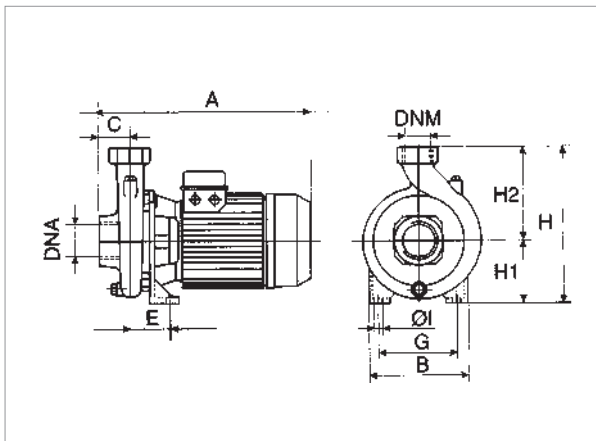

See hydraulic efficiency details on page 291.

The performance curves are based on kinematic viscosity values = 1 mm²/s and density equal to 1000 kg/m³. Curve tolerance according to ISO 9906.

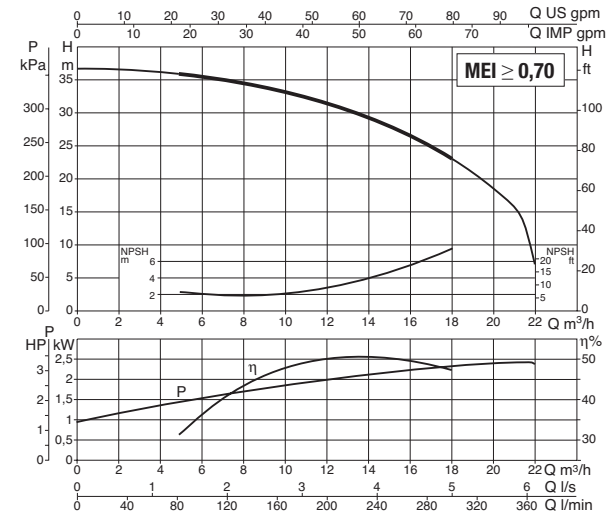

MODEL	ELECTRICAL DATA							
	POWER INPUT 50 Hz	P1 MAX kW	P2 NOMINAL		In A	MOTOR TYPE	I st. A	rpm n. 1/min.
			kW	HP				
K 36/200 T	3x230-400 V ~	3	2.2	3	9-5.2	IE2	45-26	2860

MODEL	A	B	C	E	G	ØI	H	H1	H2	DNA	DNM	PACKING DIMENSIONS			VOLUME (m ³)	WEIGHT kg
												L/A	L/B	H		
K 36/200 T	425	250	55	86	175	14	320	135	185	2" G	1 1/4" G	512	276	345	0.049	33.1

K 40/200 - SINGLE-IMPELLER CENTRIFUGAL ELECTRIC PUMPS FOR WATER SUPPLY IN DOMESTIC, CIVIL, AND INDUSTRIAL ENVIRONMENTS

Pumped liquid temperature range: from -10 °C to +50°C - Maximum ambient temperature: +40°C

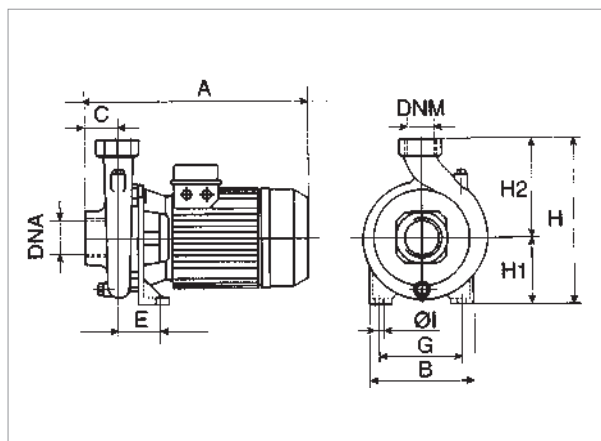

See hydraulic efficiency details on page 291.

The performance curves are based on kinematic viscosity values = 1 mm²/s and density equal to 1000 kg/m³. Curve tolerance according to ISO 9906.

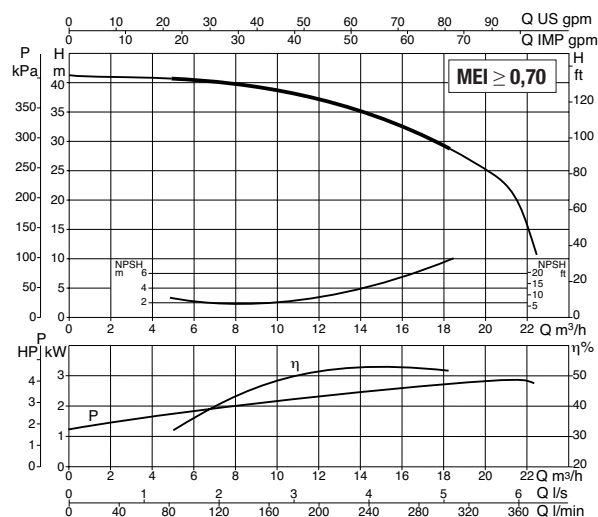

MODEL	POWER INPUT 50 Hz	P1 MAX kW	P2 NOMINAL		In A	MOTOR TYPE	I st. A	rpm n. 1/min.
			kW	HP				
K 40/200 T	3x230-400 V ~	3.5	3	4	11.1-6.4	IE2	67.5-39	2830

MODEL	A	B	C	E	G	ØI	H	H1	H2	DNA	DNM	PACKING DIMENSIONS			VOLUME (m ³)	WEIGHT kg
												L/A	L/B	H		
K 40/200	425	250	55	86	175	14	320	135	185	2" G	1 1/4" G	512	276	345	0.049	34.9

K 55/200 - SINGLE-IMPELLER CENTRIFUGAL ELECTRIC PUMPS FOR WATER SUPPLY IN DOMESTIC, CIVIL, AND INDUSTRIAL ENVIRONMENTS

Pumped liquid temperature range: from -10 °C to +50°C - Maximum ambient temperature: +40°C

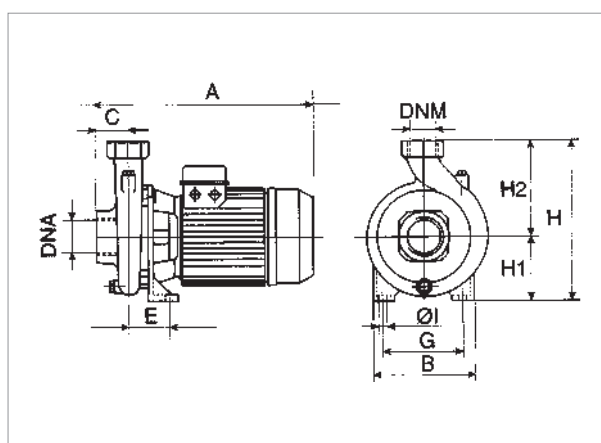

See hydraulic efficiency details on page 291.

The performance curves are based on kinematic viscosity values = 1 mm²/s and density equal to 1000 kg/m³. Curve tolerance according to ISO 9906.

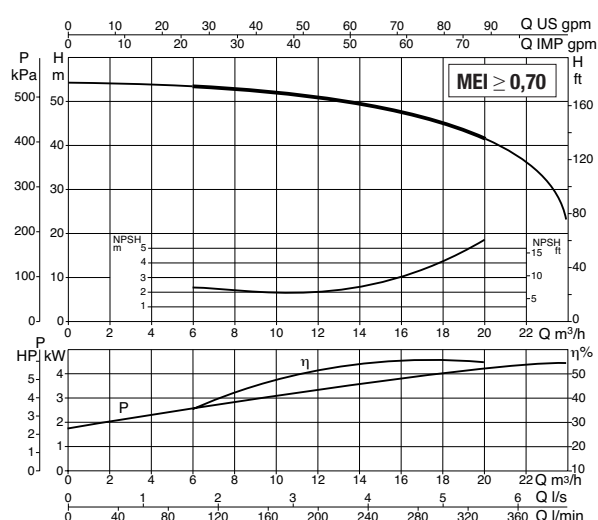

MODEL	POWER INPUT 50 Hz	P1 MAX kW	P2 NOMINAL		In A	MOTOR TYPE	I st. A	rpm n. 1/min.
			kW	HP				
K 55/200 T	3x230-400 V ~	5.1	4	5.5	16.3-9.4	IE2	104-60	2880

MODEL	A	B	C	E	G	ØI	H	H1	H2	DNA	DNM	PACKING DIMENSIONS			VOLUME (m ³)	WEIGHT kg
												L/A	L/B	H		
K 55/200	425	250	55	86	175	14	320	135	185	2" G	1 1/4" G	512	276	345	0.049	39

K 14/400 - SINGLE-IMPELLER CENTRIFUGAL ELECTRIC PUMPS FOR WATER SUPPLY IN DOMESTIC, CIVIL, AND INDUSTRIAL ENVIRONMENTS

Pumped liquid temperature range: from -10 °C to +50°C - Maximum ambient temperature: +40°C

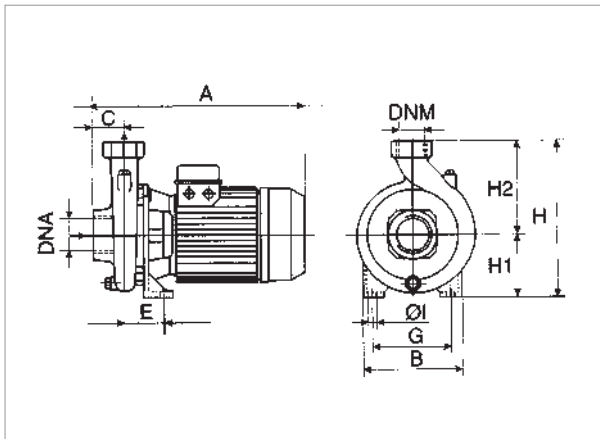

See hydraulic efficiency details on page 291.

The performance curves are based on kinematic viscosity values = 1 mm²/s and density equal to 1000 kg/m³. Curve tolerance according to ISO 9906.

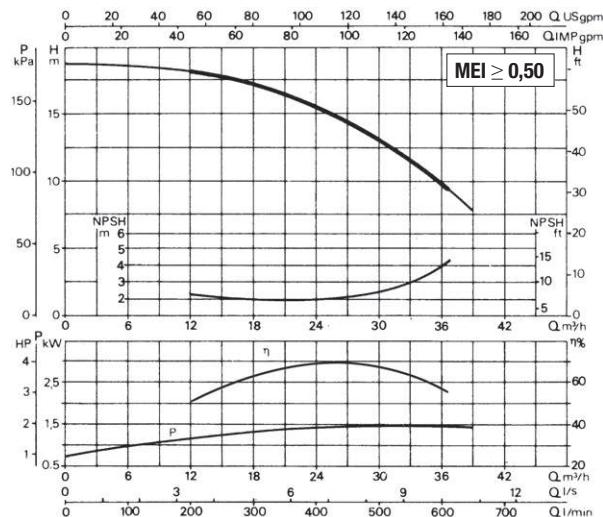

MODEL	ELECTRICAL DATA									
	POWER INPUT 50 Hz	P1 MAX kW	P2 NOMINAL		In A	MOTOR TYPE	I st. A	rpm n. 1/min.	CAPACITOR	
			kW	HP					µF	Vc
K 14/400 M	1x220-240 V ~	2.1	1.85	2.5	9.5	-	38	2850	40	450
K 14/400 T	3x230-400 V ~	2.1	1.85	2.5	7-4	IE2	37.5-21.7	2850	-	-

MODEL	A	B	C	E	G	ØI	H	H1	H2	DNA	DNM	PACKING DIMENSIONS			VOLUME (m ³)	WEIGHT kg
												L/A	L/B	H		
K 14/400 M	430	200	62	74	120	11	270	105	165	2" G	2" G	427	246	307	0.032	24.5
K 14/400 T	358	200	62	74	120	11	270	105	165	2" G	2" G	427	246	307	0.032	22

K 11/500 - SINGLE-IMPELLER CENTRIFUGAL ELECTRIC PUMPS FOR WATER SUPPLY IN DOMESTIC, CIVIL, AND INDUSTRIAL ENVIRONMENTS

Pumped liquid temperature range: from -10 °C to +50°C - Maximum ambient temperature: +40°C

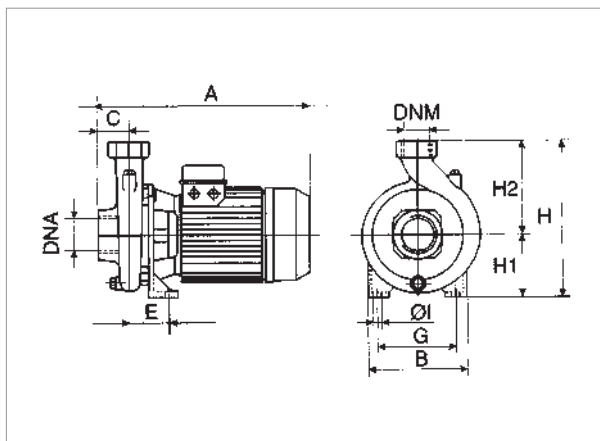

See hydraulic efficiency details on page 291.

The performance curves are based on kinematic viscosity values = 1 mm²/s and density equal to 1000 kg/m³. Curve tolerance according to ISO 9906.

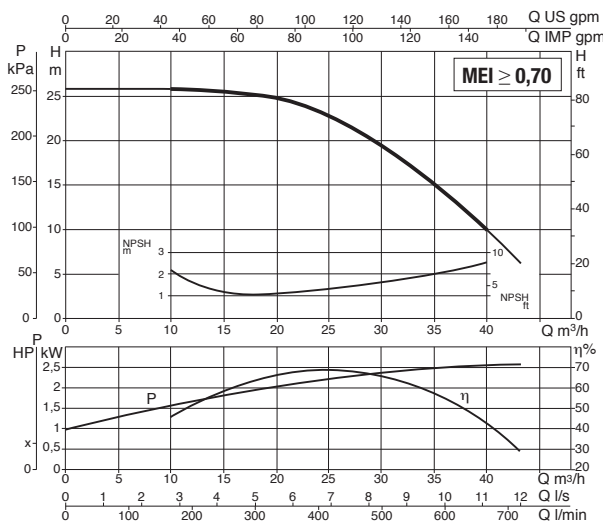

MODEL	ELECTRICAL DATA							
	POWER INPUT 50 Hz	P1 MAX kW	P2 NOMINAL		In A	MOTOR TYPE	I st. A	rpm n. 1/min.
			kW	HP				
K 11/500 T	3x230-400 V ~	2.9	2.2	3	9.3-5.4	IE2	45-26	2950

MODEL	A	B	C	E	G	ØI	H	H1	H2	DNA	DNM	PACKING DIMENSIONS			VOLUME (m ³)	WEIGHT kg
												L/A	L/B	H		
K 11/500	440	240	62	100	155	14	312	132	180	2 1/2" G	2" G	512	286	345	0.049	34.2

K 18/500 - SINGLE-IMPELLER CENTRIFUGAL ELECTRIC PUMPS FOR WATER SUPPLY IN DOMESTIC, CIVIL, AND INDUSTRIAL ENVIRONMENTS

Pumped liquid temperature range: from -10 °C to +50°C - Maximum ambient temperature: +40°C

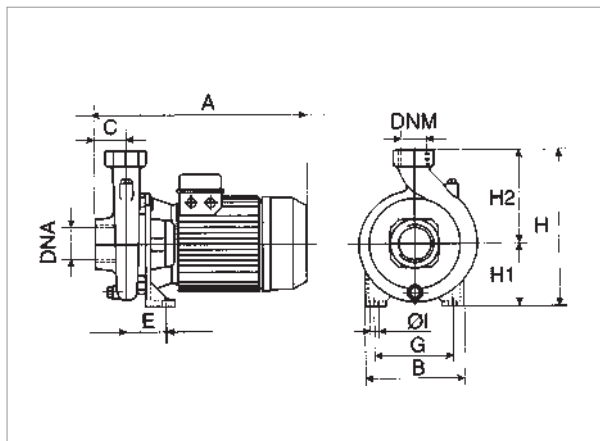

See hydraulic efficiency details on page 291.

The performance curves are based on kinematic viscosity values = 1 mm²/s and density equal to 1000 kg/m³. Curve tolerance according to ISO 9906.

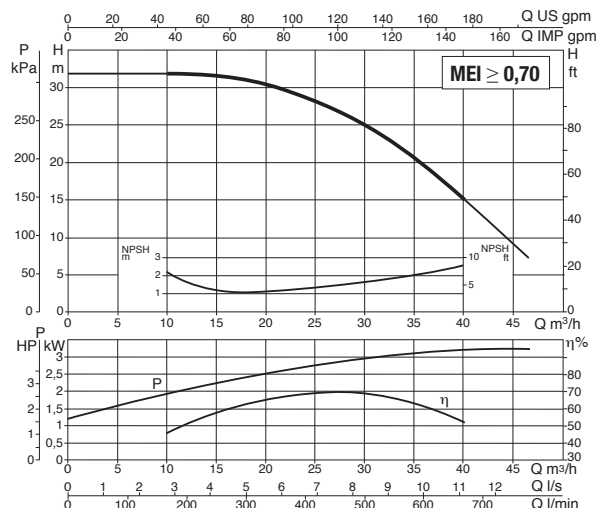

MODEL	POWER INPUT 50 Hz	P1 MAX kW	P2 NOMINAL		In A	MOTOR TYPE	I st. A	rpm n. 1/min.
			kW	HP				
K 18/500 T	3x230-400 V ~	3.8	3	4	13-7.5	IE2	67.5-39	2950

MODEL	A	B	C	E	G	ØI	H	H1	H2	DNA	DNM	PACKING DIMENSIONS			VOLUME (m ³)	WEIGHT kg
												L/A	L/B	H		
K 18/500	440	240	62	100	155	14	312	132	180	2 1/2" G	2" G	512	286	345	0.049	36.6

K 28/500 - SINGLE-IMPELLER CENTRIFUGAL ELECTRIC PUMPS FOR WATER SUPPLY IN DOMESTIC, CIVIL, AND INDUSTRIAL ENVIRONMENTS

Pumped liquid temperature range: from -10 °C to +50°C - Maximum ambient temperature: +40°C

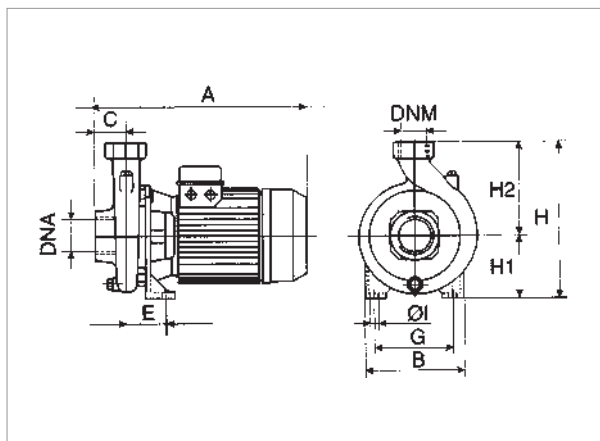

See hydraulic efficiency details on page 291.

The performance curves are based on kinematic viscosity values = 1 mm²/s and density equal to 1000 kg/m³. Curve tolerance according to ISO 9906.

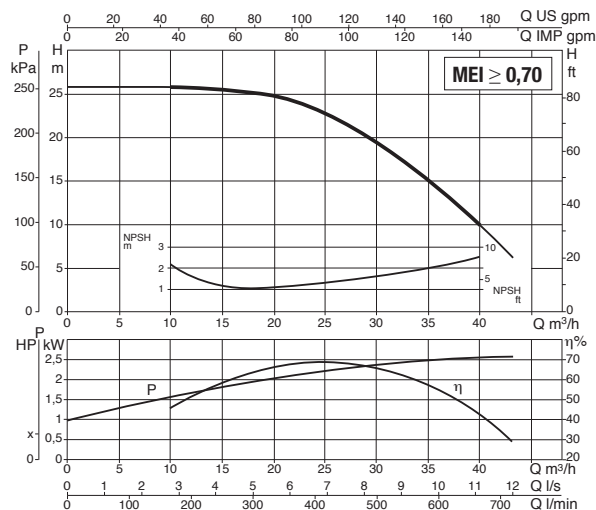

MODEL	POWER INPUT 50 Hz	P1 MAX kW	P2 NOMINAL		In A	MOTOR TYPE	I st. A	rpm n. 1/min.	CAPACITOR	
			kW	HP					µF	Vc
K 28/500 T	3x230-400 V ~	4.55	4	5.5	13.7-8	IE2	104-60	2950	-	-

MODEL	A	B	C	E	G	ØI	H	H1	H2	DNA	DNM	PACKING DIMENSIONS			VOLUME (m ³)	WEIGHT kg
												L/A	L/B	H		
K 28/500	440	240	62	100	155	14	312	132	180	2 1/2" G	2" G	512	286	345	0.049	40.6

K 40/400 - SINGLE-IMPELLER CENTRIFUGAL ELECTRIC PUMPS FOR WATER SUPPLY IN DOMESTIC, CIVIL, AND INDUSTRIAL ENVIRONMENTS

Pumped liquid temperature range: from -10 °C to +50°C - Maximum ambient temperature: +40°C

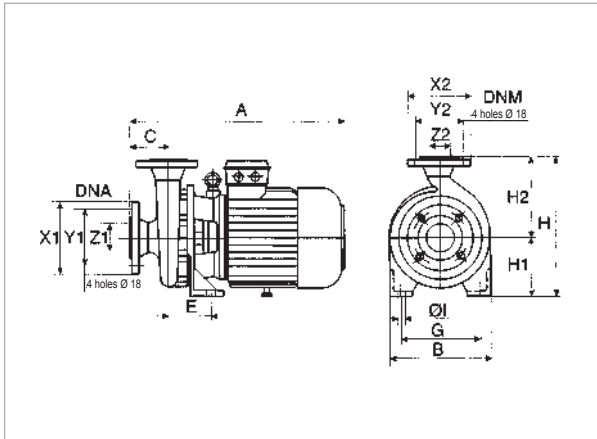

See hydraulic efficiency details on page 291.

The performance curves are based on kinematic viscosity values = 1 mm²/s and density equal to 1000 kg/m³. Curve tolerance according to ISO 9906.

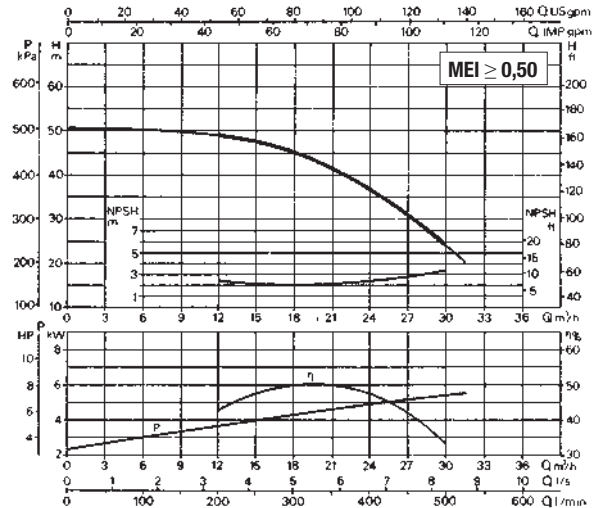

MODEL	POWER INPUT 50 Hz	P1 MAX kW	P2 NOMINAL		In A	MOTOR TYPE	I st. A	rpm n. 1/min.
			kW	HP				
K 40/400 T	3 x 400V ~ ¹	7	5.5	7.5	11.5	IE2	78	2900

MODEL	A	B	C	E	G	Ø1	H	H1	H2	DNA			DNM			PACKING DIMENSIONS			VOLUME (m ³)	WEIGHT kg
										x1	y1	z1	x2	y2	z2	L/A	L/B	H		
K 40/400	560	273	100	110	212	14	360	160	200	185	145	65	165	125	50	680	330	572	0.128	79

¹ star start-up possible (A)

K 50/400 - SINGLE-IMPELLER CENTRIFUGAL ELECTRIC PUMPS FOR WATER SUPPLY IN DOMESTIC, CIVIL, AND INDUSTRIAL ENVIRONMENTS

Pumped liquid temperature range: from -10 °C to +50°C - Maximum ambient temperature: +40°C

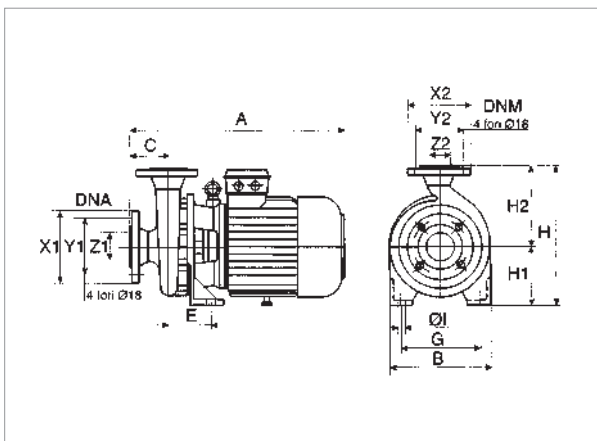

See hydraulic efficiency details on page 291.

The performance curves are based on kinematic viscosity values = 1 mm²/s and density equal to 1000 kg/m³. Curve tolerance according to ISO 9906.

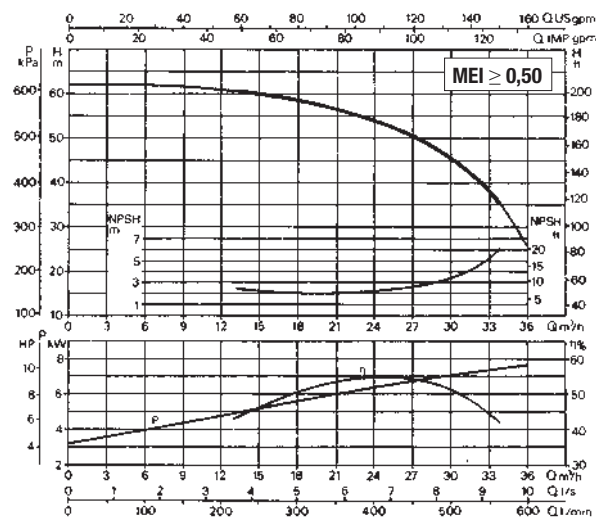

MODEL	POWER INPUT 50 Hz	P1 MAX kW	P2 NOMINAL		In A	MOTOR TYPE	I st. A	rpm n. 1/min.
			kW	HP				
K 50/400 T	3 x 400V ~ ¹	9	7.5	10	14.5	IE3	112	2910

MODEL	A	B	C	E	G	Ø1	H	H1	H2	DNA			DNM			PACKING DIMENSIONS			VOLUME (m ³)	WEIGHT kg
										x1	y1	z1	x2	y2	z2	L/A	L/B	H		
K 50/400	560	273	100	110	212	14	360	160	200	185	145	65	165	125	50	680	330	572	0.128	78.8

¹ star start-up possible (A)

K 30/800 - SINGLE-IMPELLER CENTRIFUGAL ELECTRIC PUMPS FOR WATER SUPPLY IN DOMESTIC, CIVIL, AND INDUSTRIAL ENVIRONMENTS

Pumped liquid temperature range: from -10 °C to +50°C - Maximum ambient temperature: +40°C

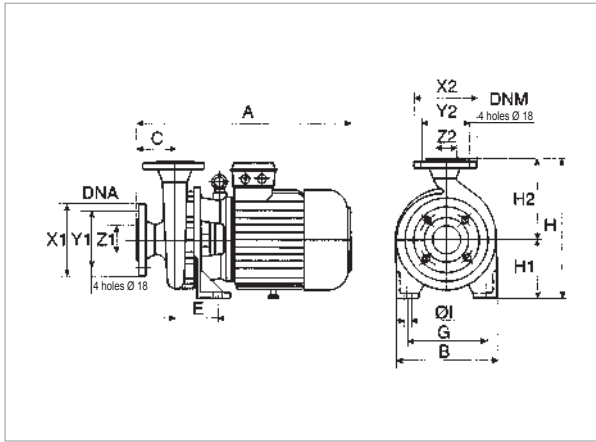

See hydraulic efficiency details on page 291.

The performance curves are based on kinematic viscosity values = 1 mm²/s and density equal to 1000 kg/m³. Curve tolerance according to ISO 9906.

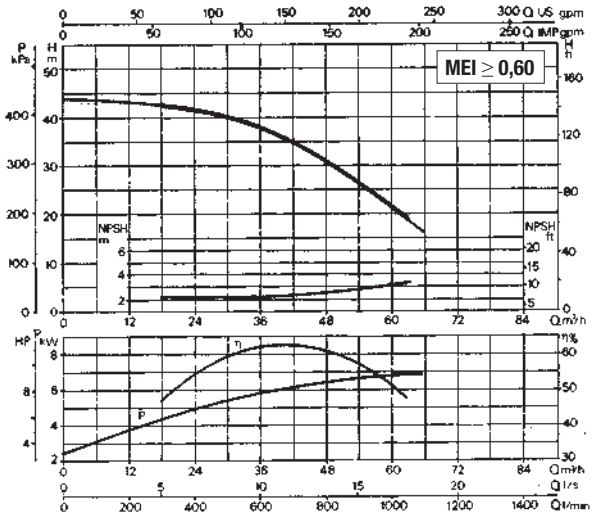

MODEL	POWER INPUT 50 Hz	P1 MAX kW	P2 NOMINAL		In A	MOTOR TYPE	I st. A	rpm n. 1/min.
			kW	HP				
K 30/800 T	3 x 400 V ~ ¹	7.6	7.5	10	13.4	IE3	112	2920

MODEL	A	B	C	E	G	ØI	H	H1	H2	DNA			DNM			PACKING DIMENSIONS			VOLUME (m ³)	WEIGHT kg
										x1	y1	z1	x2	y2	z2	L/A	L/B	H		
K 30/800	600	273	100	110	212	14	385	160	225	200	160	80	185	145	65	680	330	572	0.128	90.2

¹ star start-up possible (Δ)

K 40/800 - SINGLE-IMPELLER CENTRIFUGAL ELECTRIC PUMPS FOR WATER SUPPLY IN DOMESTIC, CIVIL, AND INDUSTRIAL ENVIRONMENTS

Pumped liquid temperature range: from -10 °C to +50°C - Maximum ambient temperature: +40°C

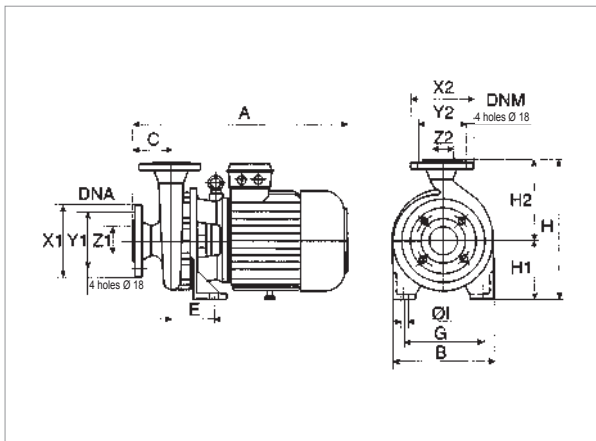

See hydraulic efficiency details on page 291.

The performance curves are based on kinematic viscosity values = 1 mm²/s and density equal to 1000 kg/m³. Curve tolerance according to ISO 9906.

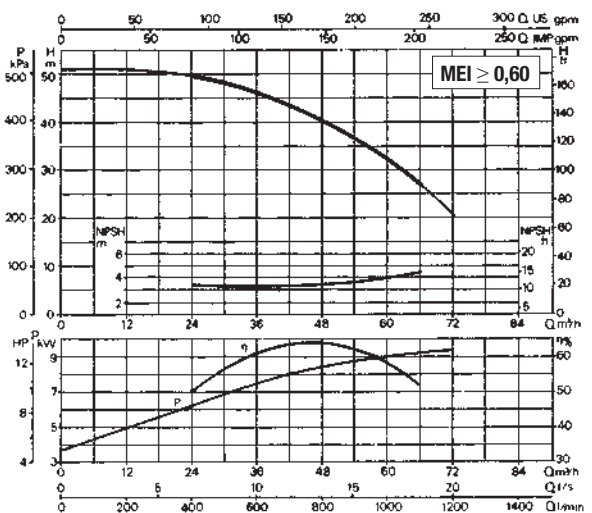

MODEL	POWER INPUT 50 Hz	P1 MAX kW	P2 NOMINAL		In A	MOTOR TYPE	I st. A	rpm n. 1/min.
			kW	HP				
K 40/800 T	3 x 400 V ~ ¹	10.2	9.2	12.5	17.1	IE3	135	2920

MODEL	A	B	C	E	G	I	H	H1	H2	DNA			DNM			PACKING DIMENSIONS			VOLUME (m ³)	WEIGHT kg
										x1	y1	z1	x2	y2	z2	L/A	L/B	H		
K 40/800	600	273	100	110	212	14	385	160	225	200	160	80	185	145	65	680	330	572	0.128	95

¹ star start-up possible (Δ)

K 50/800 - SINGLE-IMPELLER CENTRIFUGAL ELECTRIC PUMPS FOR WATER SUPPLY IN DOMESTIC, CIVIL, AND INDUSTRIAL ENVIRONMENTS

Pumped liquid temperature range: from -10 °C to +50°C - Maximum ambient temperature: +40°C

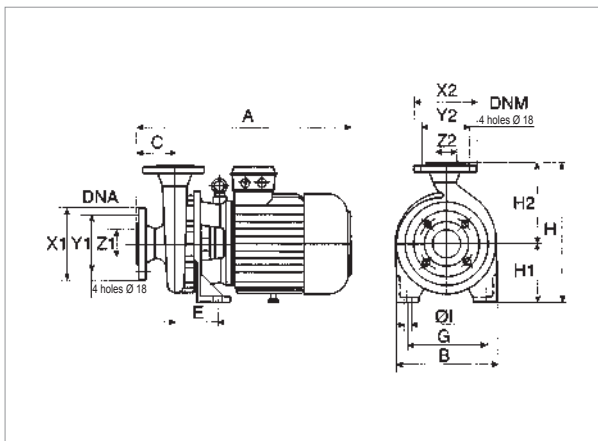

See hydraulic efficiency details on page 291.

The performance curves are based on kinematic viscosity values = 1 mm²/s and density equal to 1000 kg/m³. Curve tolerance according to ISO 9906.

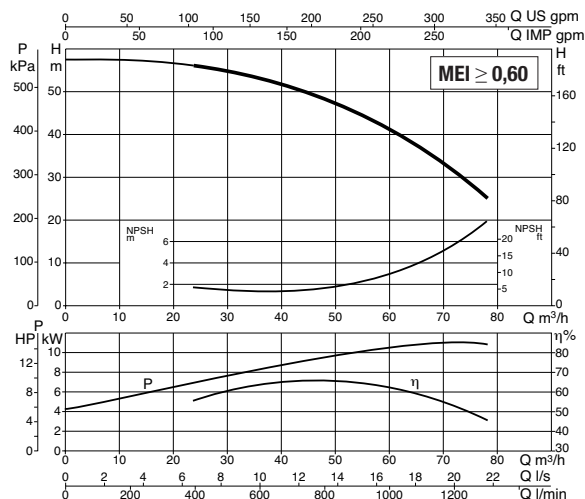

MODEL	POWER INPUT 50 Hz	P1 MAX kW	P2 NOMINAL		In A	MOTOR TYPE	I st. A	rpm n. 1/min.
			kW	HP				
K 50/800 T	3 x 400 V ~ 1	11.6	11	15	20	IE3	193	2900

MODEL	A	B	C	E	G	Ø1	H	H1	H2	DNA			DNM			PACKING DIMENSIONS			VOLUME (m ³)	WEIGHT kg
										x1	y1	z1	x2	y2	z2	L/A	L/B	H		
K 50/800	600	273	100	110	212	14	385	160	225	200	160	80	185	145	65	680	330	572	0.128	104.3

¹ star start-up possible (A)

K 20/1200 - SINGLE-IMPELLER CENTRIFUGAL ELECTRIC PUMPS FOR WATER SUPPLY IN DOMESTIC, CIVIL, AND INDUSTRIAL ENVIRONMENTS

Pumped liquid temperature range: from -10 °C to +50°C - Maximum ambient temperature: +40°C

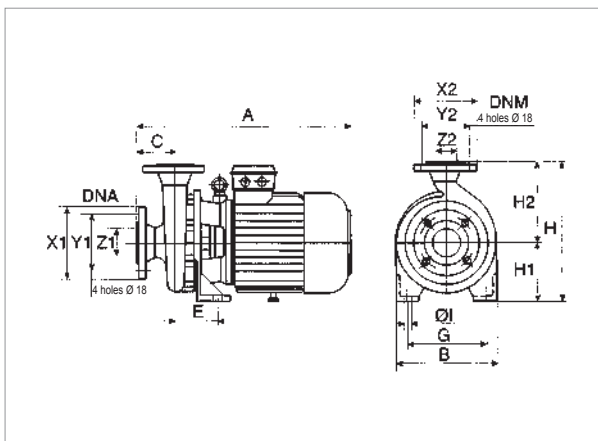

See hydraulic efficiency details on page 291.

The performance curves are based on kinematic viscosity values = 1 mm²/s and density equal to 1000 kg/m³. Curve tolerance according to ISO 9906.

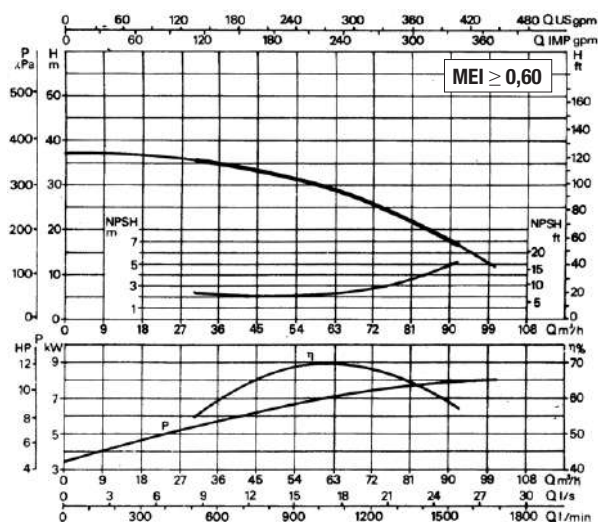

MODEL	POWER INPUT 50 Hz	P1 MAX kW	P2 NOMINAL		In A	MOTOR TYPE	I st. A	rpm n. 1/min.
			kW	HP				
K 20/1200 T	3 x 400 V ~ 1	8.3	7.5	10	15	IE3	112	2920

MODEL	A	B	C	E	G	Ø1	H	H1	H2	DNA			DNM			PACKING DIMENSIONS			VOLUME (m ³)	WEIGHT kg
										x1	y1	z1	x2	y2	z2	L/A	L/B	H		
K 20/1200	600	273	100	110	212	14	385	160	225	200	160	80	185	145	65	680	330	572	0.128	88

¹ star start-up possible (A)

K 25/1200 - SINGLE-IMPELLER CENTRIFUGAL ELECTRIC PUMPS FOR WATER SUPPLY IN DOMESTIC, CIVIL, AND INDUSTRIAL ENVIRONMENTS

Pumped liquid temperature range: from -10 °C to +50°C - Maximum ambient temperature: +40°C

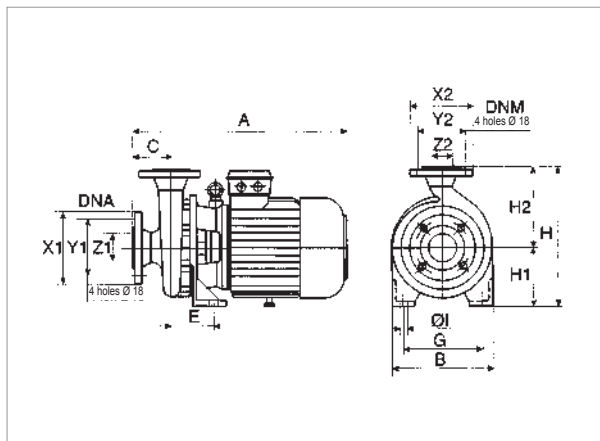

See hydraulic efficiency details on page 291.

The performance curves are based on kinematic viscosity values = 1 mm²/s and density equal to 1000 kg/m³. Curve tolerance according to ISO 9906.

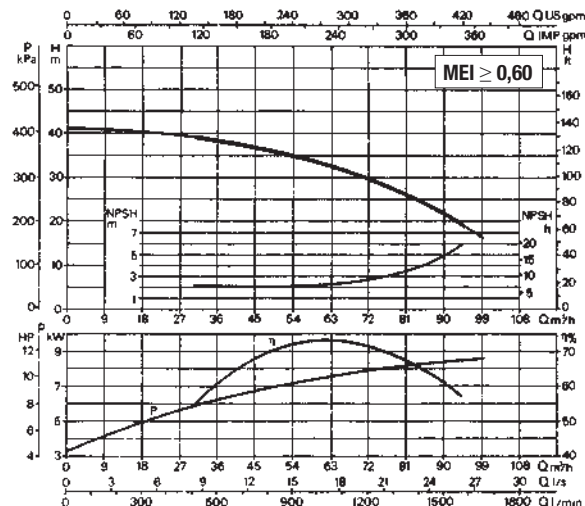

MODEL	POWER INPUT 50 Hz	P1 MAX kW	P2 NOMINAL		I _n A	MOTOR TYPE	I _{st.} A	rpm n. 1/min.
			kW	HP				
K 25/1200 T	3 x 400 V ~ ¹	9.1	9.2	12.5	17.3	IE3	135	2910

MODEL	A	B	C	E	G	Ø1	H	H1	H2	DNA			DNM			PACKING DIMENSIONS			VOLUME (m ³)	WEIGHT kg
										x1	y1	z1	x2	y2	z2	L/A	L/B	H		
K 25/1200	600	273	100	110	212	14	385	160	225	200	160	80	185	145	65	680	330	572	0.128	94

¹ star start-up possible (Λ)

K 35/1200 - SINGLE-IMPELLER CENTRIFUGAL ELECTRIC PUMPS FOR WATER SUPPLY IN DOMESTIC, CIVIL, AND INDUSTRIAL ENVIRONMENTS

Pumped liquid temperature range: from -10 °C to +50°C - Maximum ambient temperature: +40°C

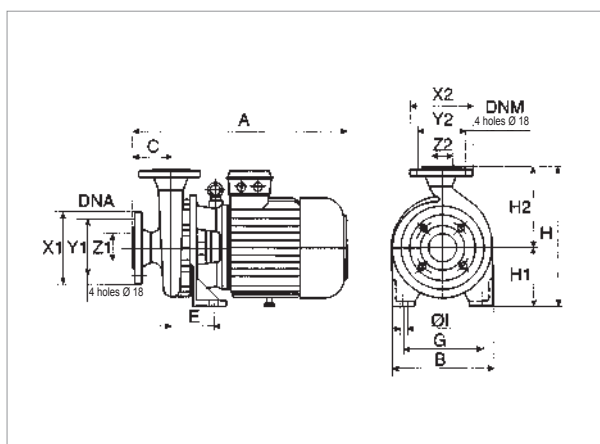

See hydraulic efficiency details on page 291.

The performance curves are based on kinematic viscosity values = 1 mm²/s and density equal to 1000 kg/m³. Curve tolerance according to ISO 9906.

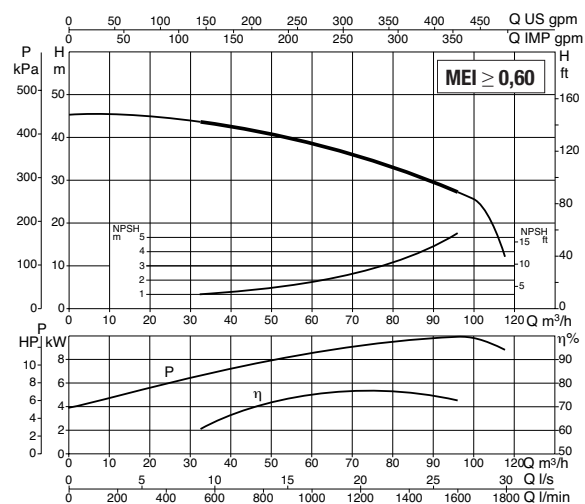

MODEL	POWER INPUT 50 Hz	P1 MAX kW	P2 NOMINAL		I _n A	MOTOR TYPE	I _{st.} A	rpm n. 1/min.
			kW	HP				
K 35/1200 T	3 x 400 V ~ ¹	10.6	11	15	18.4	IE3	193	2900

MODEL	A	B	C	E	G	Ø1	H	H1	H2	DNA			DNM			PACKING DIMENSIONS			VOLUME (m ³)	WEIGHT kg
										x1	y1	z1	x2	y2	z2	L/A	L/B	H		
K 35/1200	600	273	100	110	212	14	385	160	225	200	160	80	185	145	65	680	330	572	0.128	100

¹ star start-up possible (Λ)